

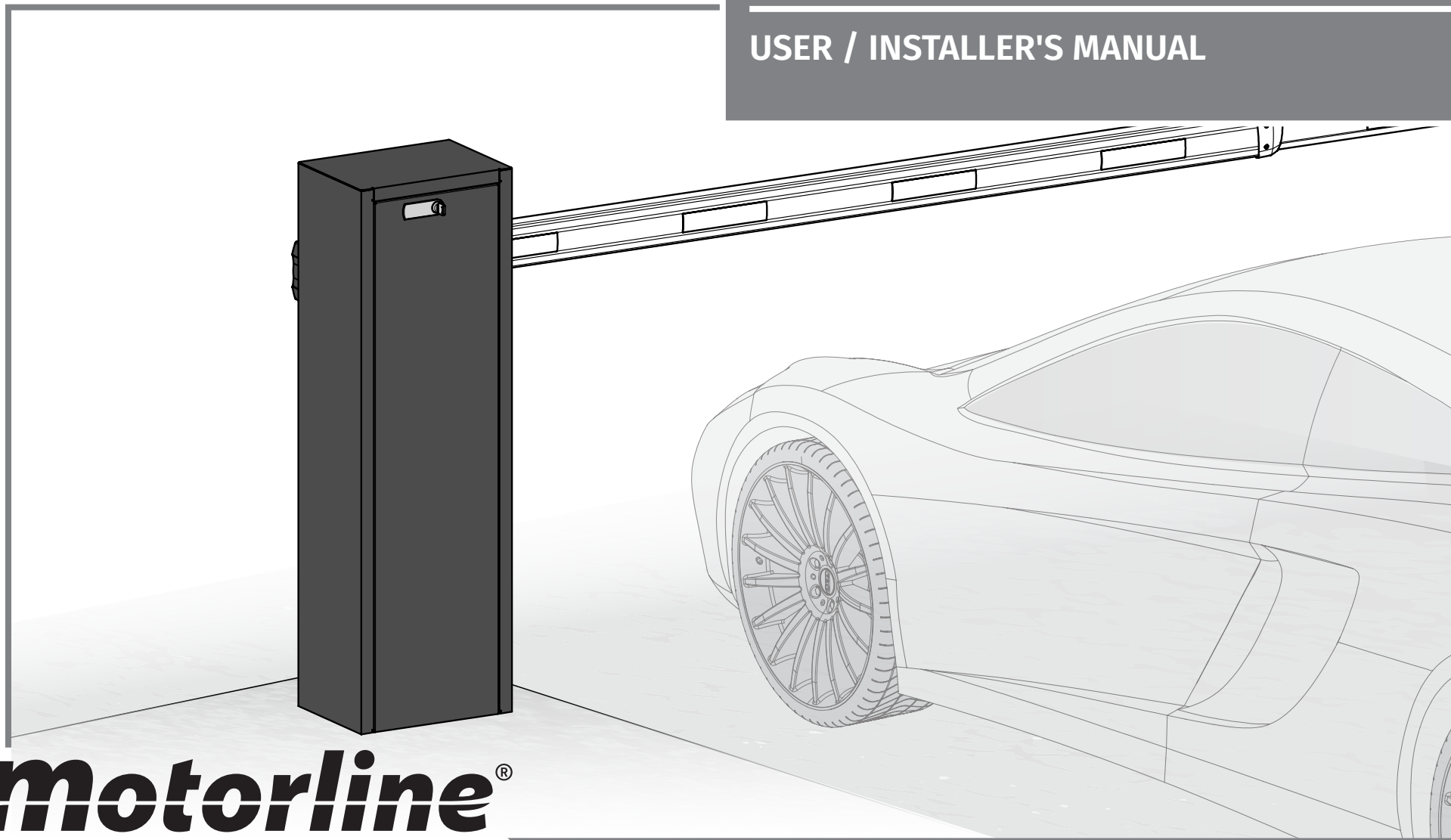

MOTIZA

USER / INSTALLER'S MANUAL







00. CONTENT

INDEX

01. SAFETY INSTRUCTIONS	1B
02. AUTOMATISM	
TECHNICAL CHARACTERISTICS	4A
COMPATIBLE COMPONENTS	4B
LOCK / UNLOCK AUTOMATISM	5A
03. INSTALLATION	
INSTALLATION MAP EXAMPLE	5B
AUTOMATISM INSTALLATION	6
BOOM POSITION	7A
INVERT BOOM POSITION	7B
BOOM MOUNTING	9
FIX BOOM SUPPORT (OPTIONAL)	10
ADJUST THE SPRINGS	11
ADJUSTING TABLES	12A
TESTING SPRING ADJUSTMENT	12B
TUNING STOPPERS AND LIMIT SWITCHES	13
POWER CABLE	14A
04. CONNECTIONS	
CONNECTION SCHEME	14B
05. TROUBLESHOOTING	
INSTRUCTIONS FOR FINAL CONSUMERS / SPECIALIZED TECHNICIANS	15

01. SAFETY INSTRUCTIONS

ATTENTION:

	This product is certified in accordance with European Community (EC) safety standards.
	This product complies with Directive 2011/65/EU of the European Parliament and of the Council, of 8 June 2011, on the restriction of the use of certain hazardous substances in electrical and electronic equipment and with Delegated Directive (EU) 2015/863 from Commission.
	(Applicable in countries with recycling systems). This marking on the product or literature indicates that the product and electronic accessories (eg. Charger, USB cable, electronic material, controls, etc.) should not be disposed of as other household waste at the end of its useful life. To avoid possible harm to the environment or human health resulting from the uncontrolled disposal of waste, separate these items from other types of waste and recycle them responsibly to promote the sustainable reuse of material resources. Home users should contact the dealer where they purchased this product or the National Environment Agency for details on where and how they can take these items for environmentally safe recycling. Business users should contact their vendor and check the terms and conditions of the purchase agreement. This product and its electronic accessories should not be mixed with other commercial waste.
	This marking indicates that the product and electronic accessories (eg. charger, USB cable, electronic material, controls, etc.) are susceptible to electric shock by direct or indirect contact with electricity. Be cautious when handling the product and observe all safety procedures in this manual.

01. SAFETY INSTRUCTIONS

GENERAL WARNINGS

- This manual contains very important safety and usage information, very important. Read all instructions carefully before beginning the installation/usage procedures and keep this manual in a safe place that it can be consulted whenever necessary.
- This product is intended for use only as described in this manual. Any other enforcement or operation that is not mentioned is expressly prohibited, as it may damage the product and put people at risk causing serious injuries.
- This manual is intended firstly for specialized technicians, and does not invalidate the user's responsibility to read the "User Norms" section in order to ensure the correct functioning of the product.
- The installation and repair of this product may be done by qualified and specialized technicians, to assure every procedure are carried out in accordance with applicable rules and norms. Nonprofessional and inexperienced users are expressly prohibited of taking any action, unless explicitly requested by specialized technicians to do so.
- Installations must be frequently inspected for unbalance and the wear signals of the cables, springs, hinges, wheels, supports and other mechanical assembly parts.
- Do not use the product if it is necessary repair or adjustment is required.
- When performing maintenance, cleaning and replacement of parts, the product must be disconnected from power supply. Also including any operation that requires opening the product cover.
- The use, cleaning and maintenance of this product may be carried out by any persons aged eight years old and over and persons whose physical, sensorial or mental capacities are lower, or by persons without any knowledge of the product, provided that these are supervision and instructions given by persons with experienced in terms of usage of the product in a safe manner and who understands the risks and dangers involved.

- Children shouldn't play with the product or opening devices to avoid the motorized door or gate from being triggered involuntarily.

WARNINGS FOR TECHNICIANS

- Before beginning the installation procedures, make sure that you have all the devices and materials necessary to complete the installation of the product.
- You should note your Protection Index (IP) and operating temperature to ensure that is suitable for the installation site.
- Provide the manual of the product to the user and let them know how to handle it in an emergency.
- If the automatism is installed on a gate with a pedestrian door, a door locking mechanism must be installed while the gate is in motion.
- Do not install the product "upside down" or supported by elements do not support its weight. If necessary, add brackets at strategic points to ensure the safety of the automatism.
- Do not install the product in explosive site.
- Safety devices must protect the possible crushing, cutting, transport and danger areas of the motorized door or gate.
- Verify that the elements to be automated (gates, door, windows, blinds, etc.) are in perfect function, aligned and level. Also verify if the necessary mechanical stops are in the appropriate places.
- The central must be installed on a safe place of any fluid (rain, moisture, etc.), dust and pests.
- You must route the various electrical cables through protective tubes, to protect them against mechanical exertions, essentially on the power supply cable. Please note that all the cables must enter the central from the bottom.
- If the automatism is to be installed at a height of more than 2,5m from the ground or other level of access, the minimum safety and health requirements for the use of work equipment workers at the work of Directive 2009/104/CE of European Parliament and of the Council of 16

01. SAFETY INSTRUCTIONS

September 2009.

- Attach the permanent label for the manual release as close as possible to the release mechanism.
- Disconnect means, such as a switch or circuit breaker on the electrical panel, must be provided on the product's fixed power supply leads in accordance with the installation rules.
- If the product to be installed requires power supply of 230Vac or 110Vac, ensure that connection is to an electrical panel with ground connection.
- The product is only powered by low voltage safety with central (only at 24V motors)

WARNINGS FOR USERS

- Keep this manual in a safe place to be consulted whenever necessary.
- If the product has contact with fluids without being prepared, it must immediately disconnect from the power supply to avoid short circuits, and consult a specialized technician.
- Ensure that technician has provided you the product manual and informed you how to handle the product in an emergency.
- If the system requires any repair or modification, unlock the automatism, turn off the power and do not use it until all safety conditions have been met.
- In the event of tripping of circuits breakers or fuse failure, locate the malfunction and solve it before resetting the circuit breaker or replacing the fuse. If the malfunction is not repairable by consult this manual, contact a technician.
- Keep the operation area of the motorized gate free while the gate is in motion, and do not create strength to the gate movement.
- Do not perform any operation on mechanical elements or hinges if the product is in motion.

RESPONSABILITY

- Supplier disclaims any liability if:
 - Product failure or deformation result from improper installation use or maintenance!
 - Safety norms are not followed in the installation, use and maintenance of the product.
 - Instructions in this manual are not followed.
 - Damaged is caused by unauthorized modifications
 - In these cases, the warranty is voided.

MOTORLINE ELECTROCELOS SA.

Travessa do Sobreiro, nº29
4755-474 Rio Côvo (Santa Eugénia)
Barcelos, Portugal

SYMBOLS LEGEND:



• Important safety notices



• Useful information



• Programming information



• Potentiometer information



• Connectors information



• Buttons information

02. AUTOMATISM

TECHNICAL CHARACTERISTICS



Motiza is an electromechanical barrier, developed with the aim of controlling vehicle access to private, industrial or commercial areas.

Automatism technical specifications:

	MOTIZA 5
• Power	150W
• Barrier power	110/230Vac 50/60Hz
• Motor voltage	24Vdc
• Noise	LpA <= 50dB (A)
• Operating Temperature	-25°C to 55°C
• Protection Level	IP54
• Working Frequency	80%
• Opening / Closing Time	5 seconds
• Max boom length	5 meters

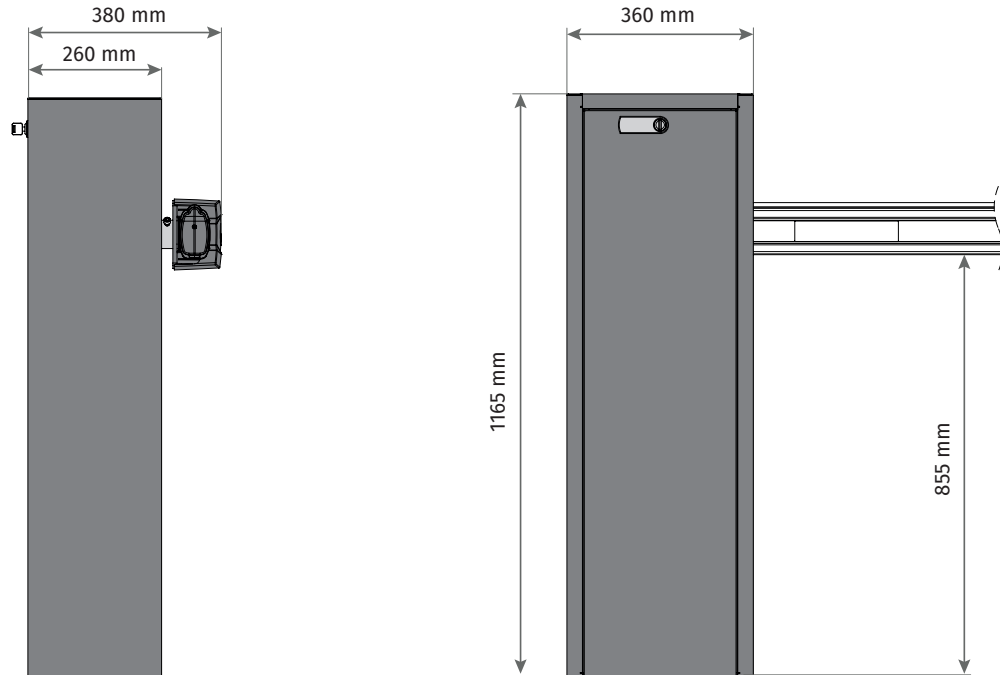

02. AUTOMATISM

COMPATIBLE COMPONENTS

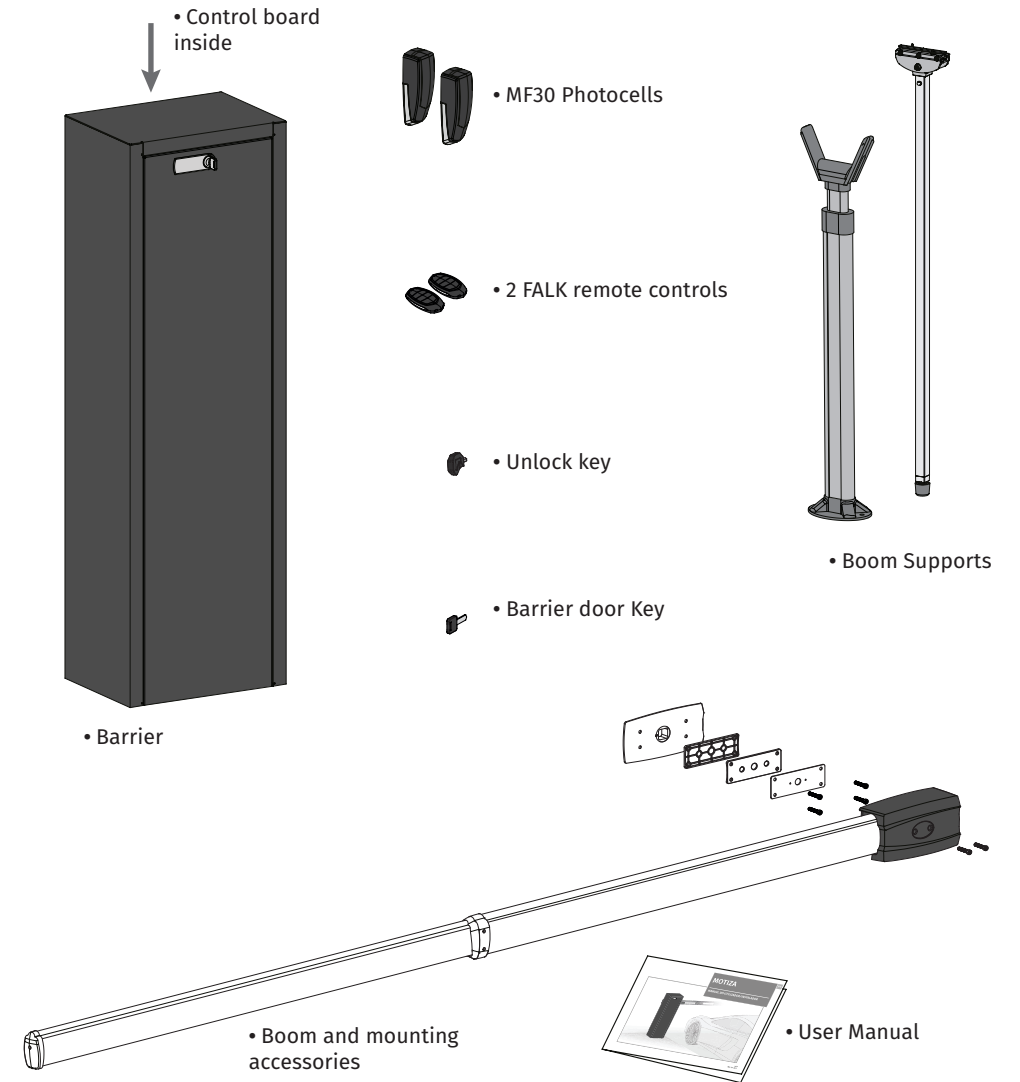

Some of these accessories may be sold separately. Consult your distributor.

02. AUTOMATISM

LOCK / UNLOCK AUTOMATISM

In an emergency or during the barrier installation / adjustment phase, it may be necessary to move the boom manually. To do so, you must unlock the operator within the barrier according to the following instructions:



Under no circumstances should you put your hands on the movement axis of the motor and springs when the barrier is connected to the power supply.

1 Unlock automatism

Insert the unlocking key into the automatism, and turn it 180° in direction "D" to unlock it.

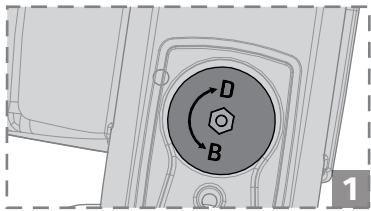

D • Motor Unlocked
B • Motor Locked

2 Block automatism

Turn the barrier release key 180° in direction "B".

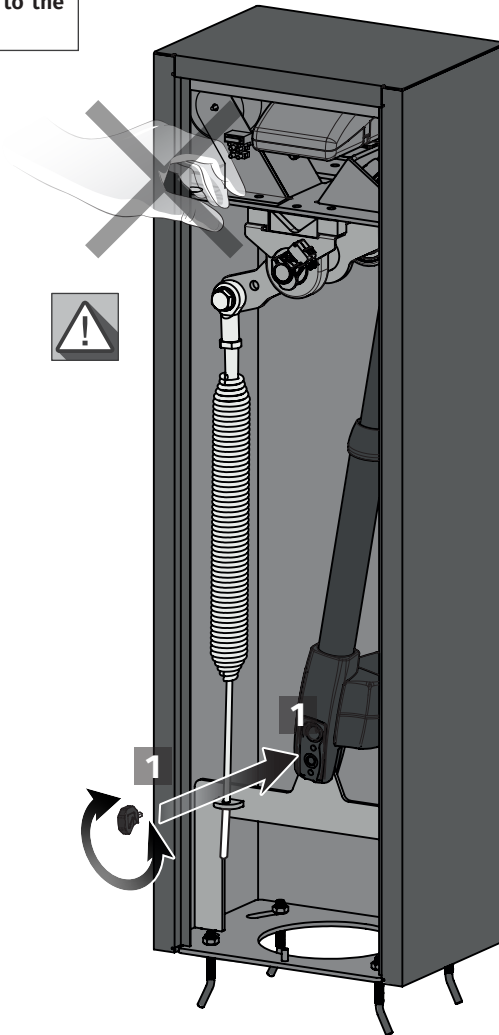

03. INSTALLATION

INSTALLATION MAP EXAMPLE

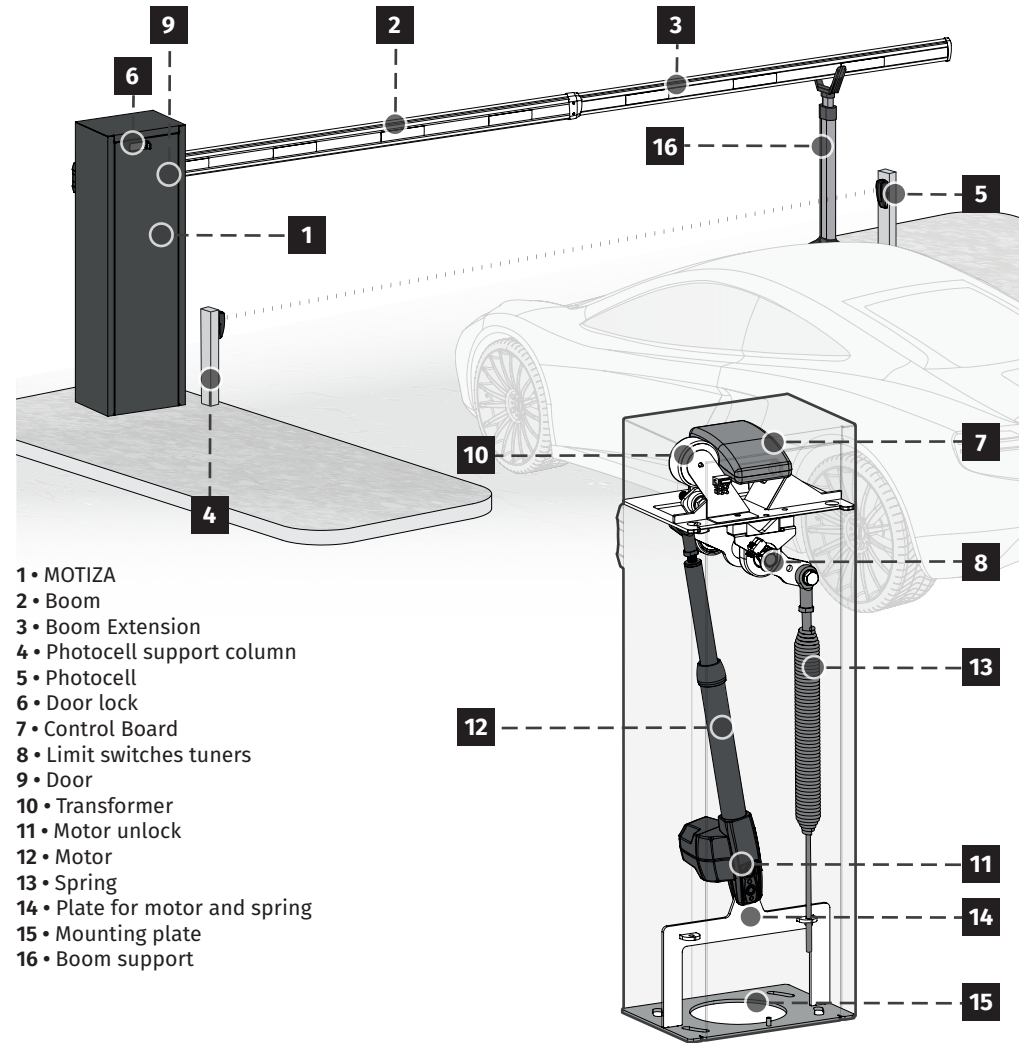

- 1 • MOTIZA
- 2 • Boom
- 3 • Boom Extension
- 4 • Photocell support column
- 5 • Photocell
- 6 • Door lock
- 7 • Control Board
- 8 • Limit switches tuners
- 9 • Door
- 10 • Transformer
- 11 • Motor unlock
- 12 • Motor
- 13 • Spring
- 14 • Plate for motor and spring
- 15 • Mounting plate
- 16 • Boom support



Use rigid and / or flexible tubs, suitable for the installation of electrical cables. Always separate low voltage cables from 230Vac cables to avoid any interference. The map shown is for a standard installation, however we do not provide all components (see kit composition on page 4B). If you need other accessories please contact us.

03. INSTALLATION

AUTOMATISM INSTALLATION

• CREATE FOUNDATION

- 1 Drill a hole of 350x460mm and 400mm (or greater) deep to create the fixing foundation.
- 2 Fill with concrete and smooth the top.
- 3 With the cement dry, follow the steps below.

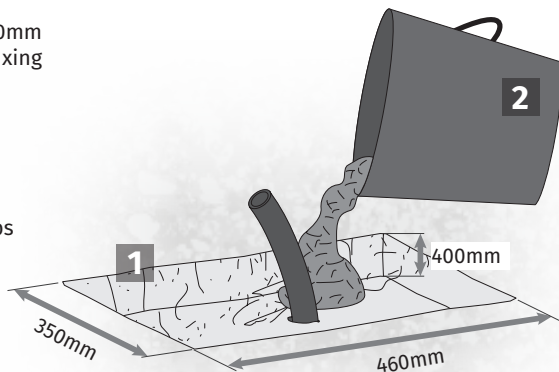

• EXISTING FOUNDATION

If you already have a foundation created, proceed as follows:

- 1 With the barrier in place, mark the holes in the foundation. Drill the foundation at these markings and apply appropriate dowels to secure the barrier.
- 2 Pass the electrical cables to connect the motor to the accessories and power supply. Leave cables of a length that ensures easy connection to the control board at the top of the barrier.
- 3 Position the barrier on the foundation leaving it centered with the wirings and fix it by applying nuts and screws from the inside of the barrier.

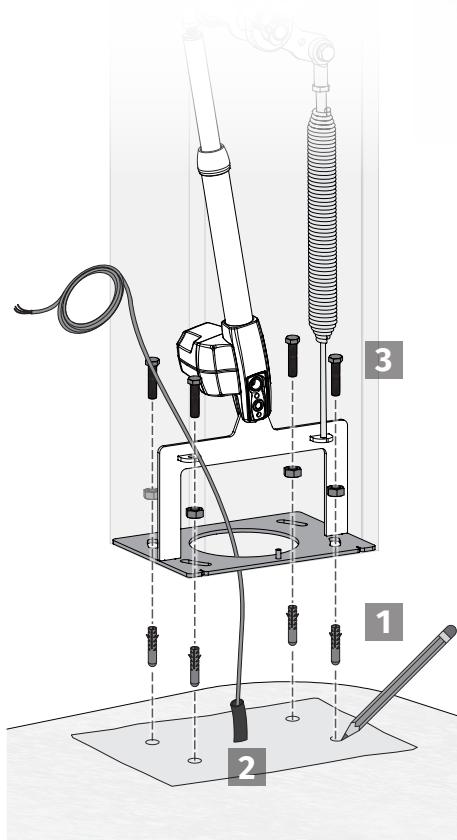

• ADJUST BARRIER POSITION

*Once fixed to the ground, the barrier is prepared to allow a position adjustment of a few degrees. Adjustment is made by turning the barrier around its center.

- 1 Give some gap to the nuts or plate tightening screws in order to be able to rotate the barrier.
- 2 Rotate the barrier to the right or left to place it at the desired point.

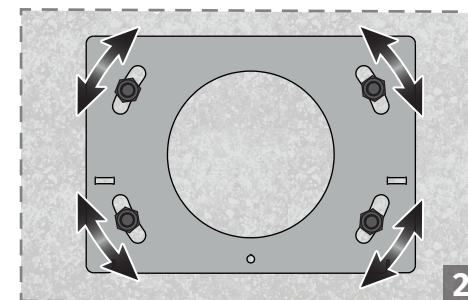

- 3 Re-tighten the nuts or screws to secure the barrier in the set position.



This adjustment should be done only when the foundation cement is dry to prevent barrier dislocation.

03. INSTALLATION

BOOM POSITION

• BOOM ON THE LEFT

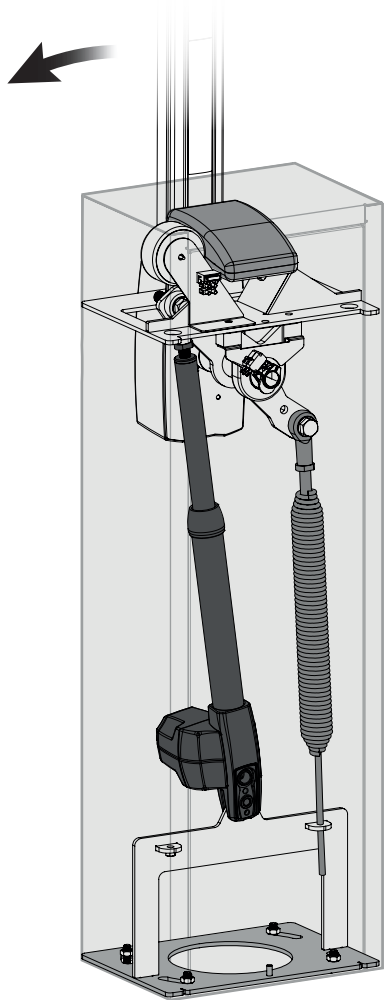

- Motor mounted on the left
- Spring mounted on the right

• BOOM ON THE RIGHT (Standard) *

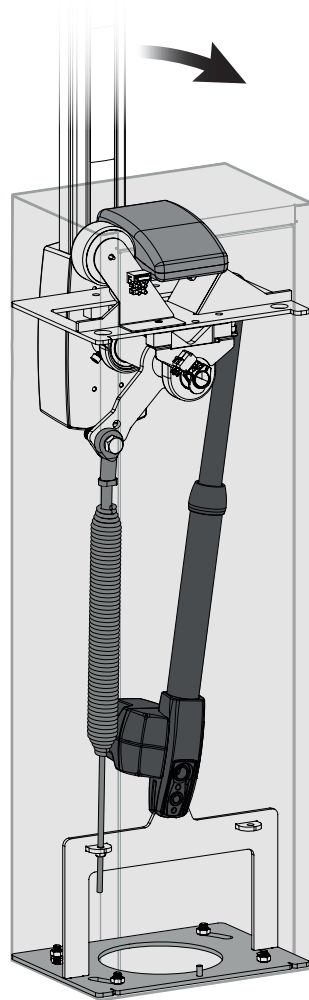

- Motor mounted on the right
- Spring mounted on the left



*If you order the barrier without specifying the position of the boom, it will be mounted on the right (DX).
If the barrier is not in the desired position follow the instructions on the next page to reverse the opening / closing direction.

03. INSTALLATION

INVERT BOOM POSITION



If the motor and spring are on the opposite side as intended, according to the diagrams on the left page, you should change the position of these components before placing the boom in the barrier.

For this, you will need to:

- 1 • Unscrew the spring
- 2 • Unscrew the motor
- 3 • Tighten the motor on the opposite side
- 4 • Tighten the spring according to the tuning tables on page 12A.



Before removing the spring, do these steps:

- 1 • Extend the motor arm to the maximum so that the lever is tilted at 45°.
- 2 • Ensure motor is in locked position
- 3 • Disconnect the boom from any power supply

These safety steps ensure that the spring is at the lowest point of tension and that the boom will not come down (close) by itself!

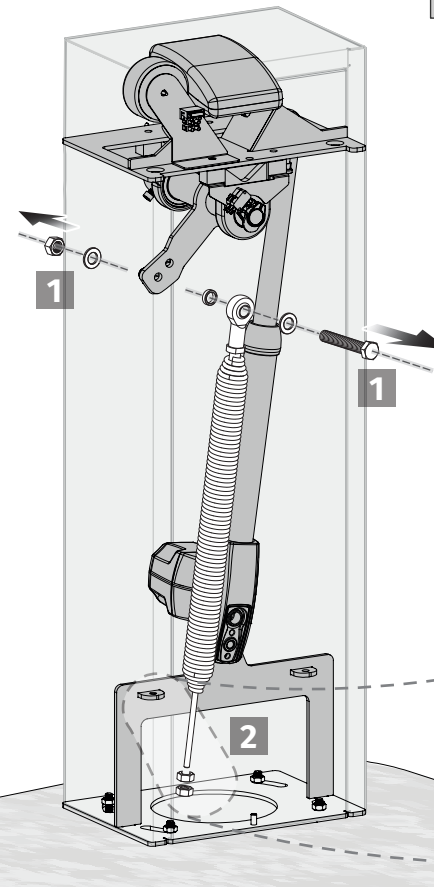

• REMOVE LEVER SPRING

- 1 Loosen the spring locking nut on the top and remove the screws and washers to loosen the spring.
- 2 Loosen and remove the tuning nuts (underside) to remove the spring.

03. INSTALLATION

INVERT BOOM POSITION

• INVERT MOTOR

- 3 Unlock the motor (page 5B).
- 4 Loosen the screw that secures the motor tip to the lever, as well as the washers and nuts.
- 5 Retighten the motor tip to the lever in one of the holes on the other side with the same screw, washers and nut.

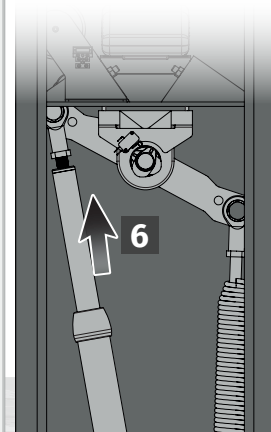
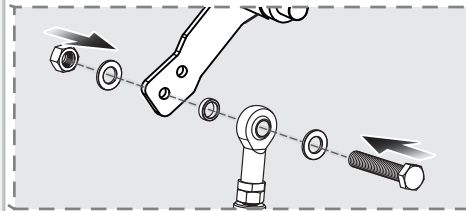
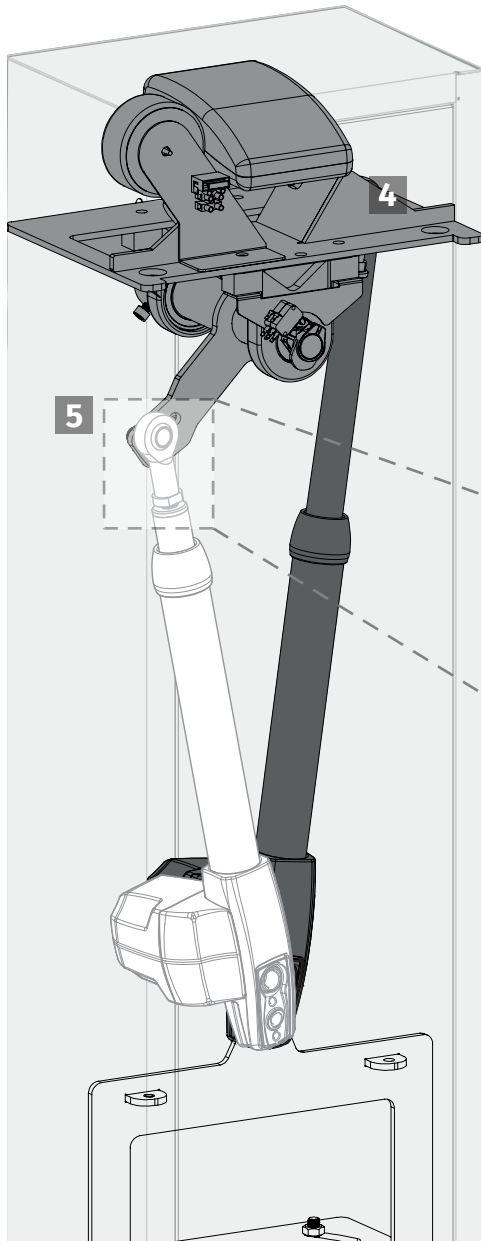

- 6 Once attached to the lever, fully extend the motor and lock it so that the lever is in this position.

• APPLY SPRINGS

- 7 See the table on page 12A for required spring adjustment as a function of boom length.
- 8 Fix the spring to the lever, respecting the indications in this table, using screws and washers according to drawing A above.
- 9 Pass the spring M8 rod through the respective hole in the lower plate, and place two M8 nuts on the spring.
In this step, do not tighten these nuts to make it easier to move the boom during installation. See page 12A for how to adjust the spring.

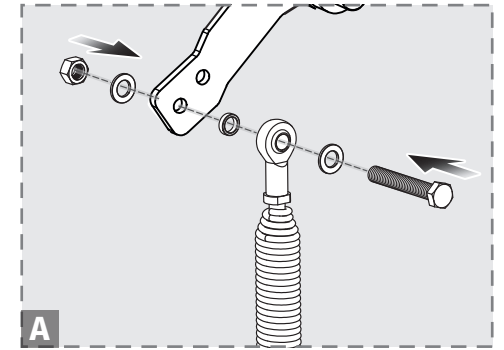
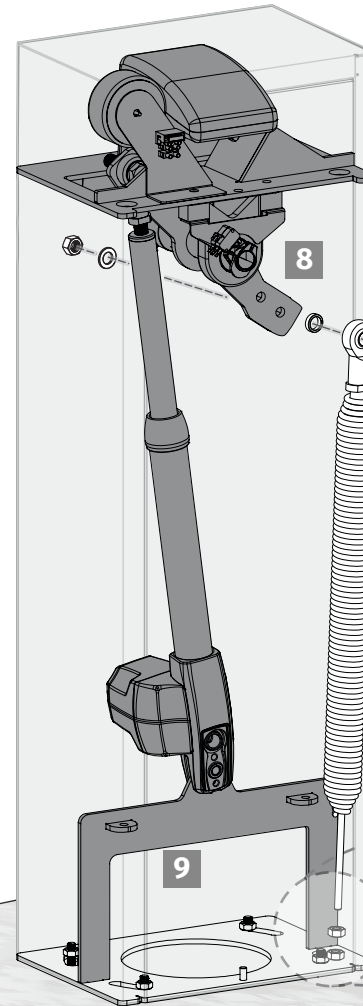

A • SPRING APPLICATION

- 7 See the table on page 12A for required spring adjustment as a function of boom length.
- 8 Fix the spring to the lever, respecting the indications in this table, using screws and washers according to drawing A above.

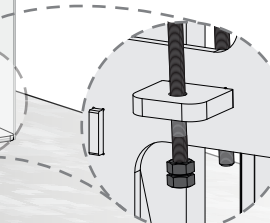

03. INSTALLATION

BOOM MOUNTING

• REVERSE BOOM SUPPORT

1

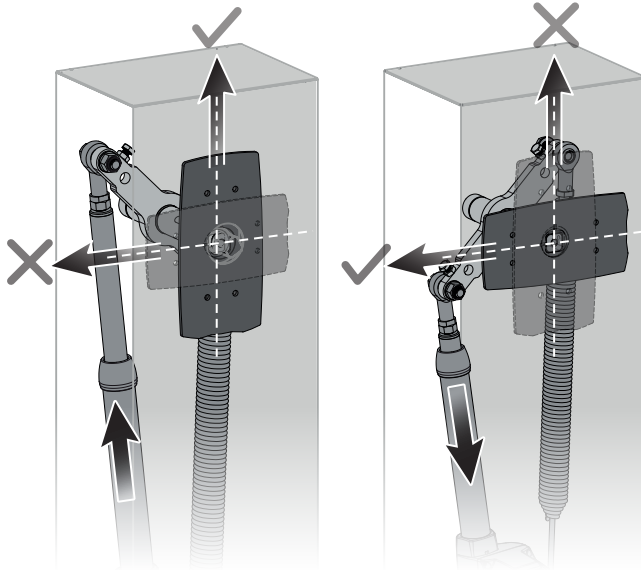

STRETCHED MOTOR

• Vertical Plate

RETRACTED MOTOR

• Horizontal plate

1 • Make sure that the boom support position corresponds to the motor position (stretched or retracted) according to the images above.

*If the boom support is in the wrong position, the support plate must be reversed.
To do this follow the steps below.*

2 • Remove the support by unscrewing the two bushing pins.

3 • Replace the support on the shaft in the correct position.

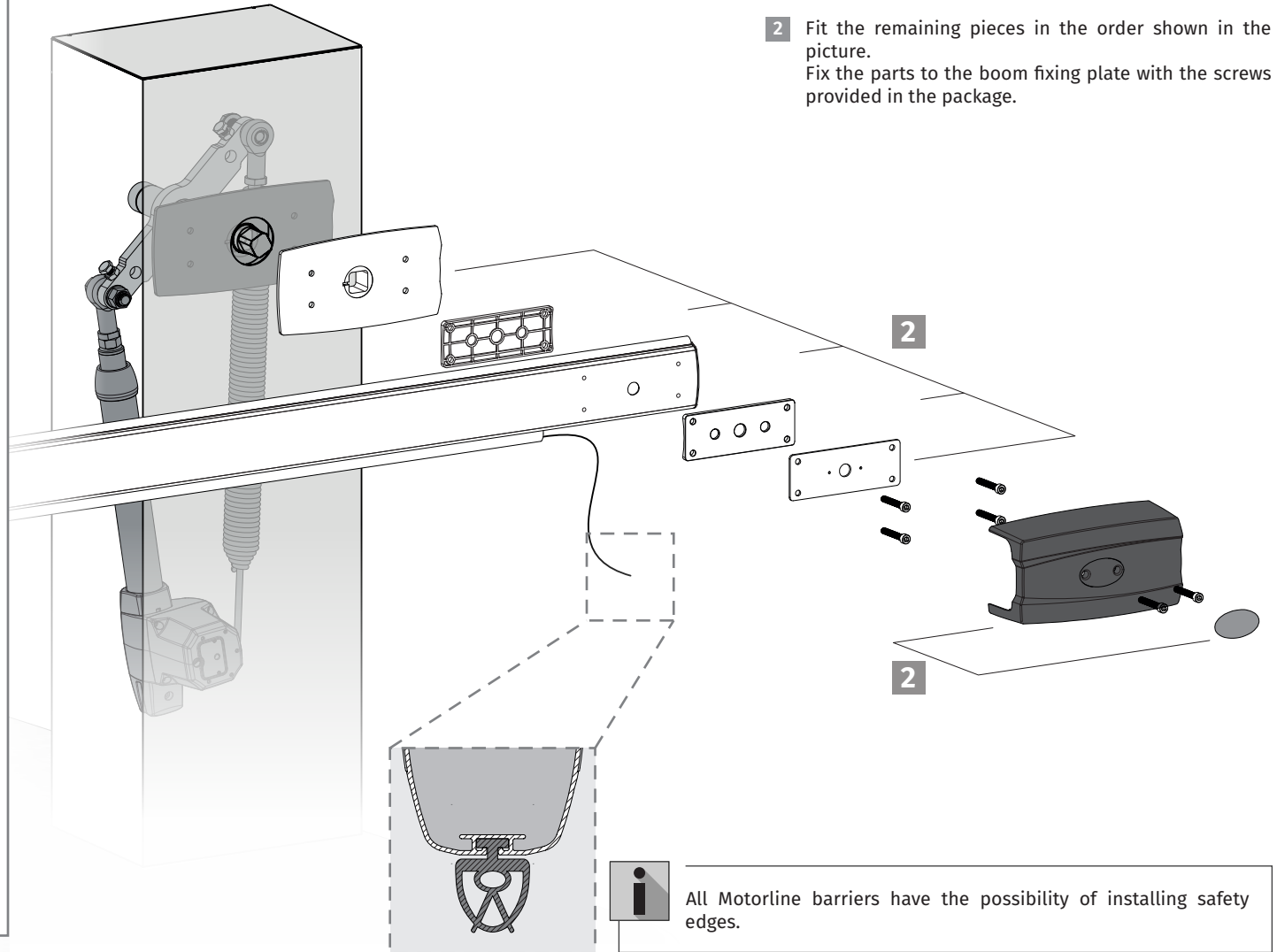

2 Fit the remaining pieces in the order shown in the picture.
Fix the parts to the boom fixing plate with the screws provided in the package.



All Motorline barriers have the possibility of installing safety edges.

03. INSTALLATION

FIX BOOM SUPPORT (OPTIONAL)

• SET EXTENDING BOOM LENGTH

- 1 Start by establishing the length of the boom so that you can then place the support, as visible in the image below.
The boom should exceed the position of the support arm by 50mm.
- 2 After placing the boom to the desired size, secure it with the two self-tapping screws to the fixed part of the boom.

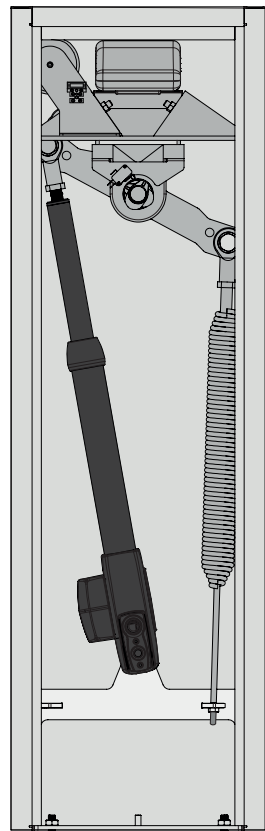
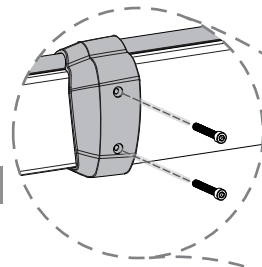

• BOOM SUPPORT (FIXED) APPLICATION

When the boom length is established, define the location of fixing the boom support to the ground.

- 3 Drill two holes at the installation location to fix the support and fix it.



All barriers must use mobile or fixed support.

• ADJUST SUPPORT (FIXED) HEIGHT

If the height of the support arm is misaligned to the height of the boom you will have to adjust the arm height. To do this follow these steps:

- 4 Loosen the support arm locking pin with a hex wrench.
- 5 Raise or lower the support arm to place the support to the height necessary to support the barrier.
- 6 Tighten the support arm locking pin to lock the support in the set position.

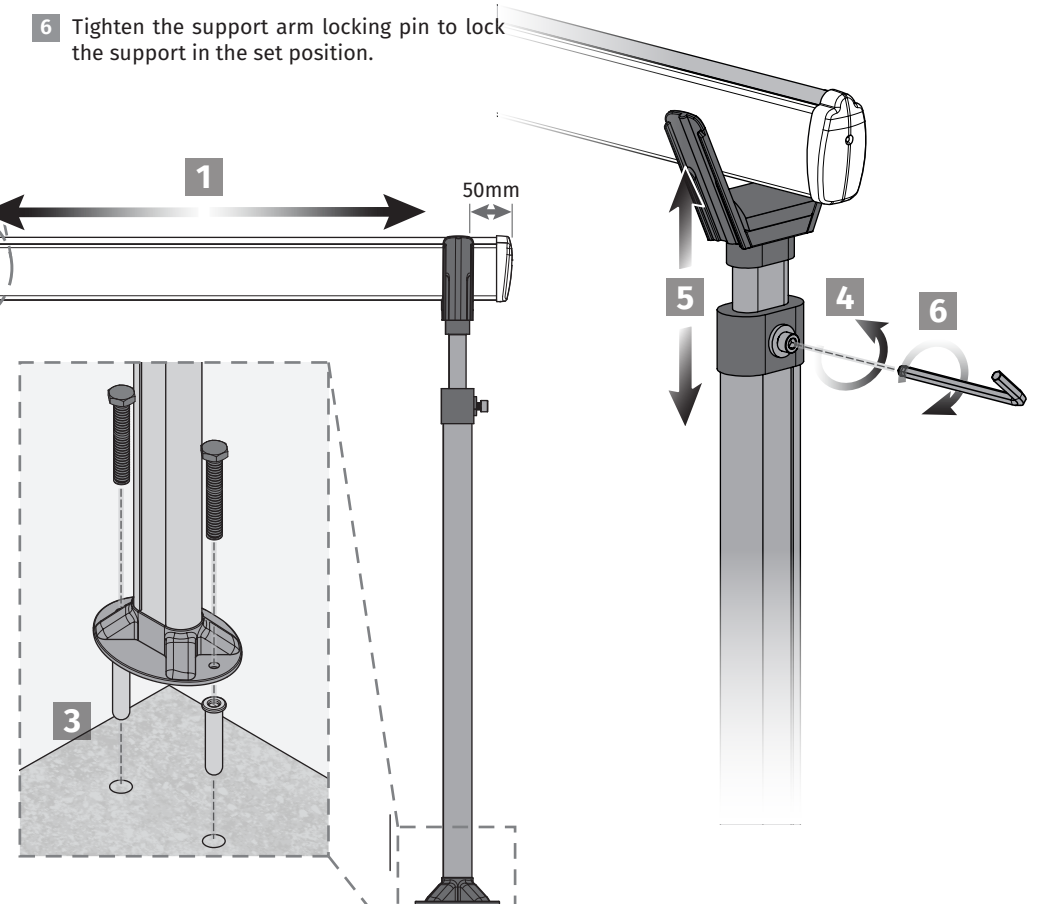

03. INSTALLATION

ADJUST THE SPRING

Before adjusting the spring, manually place the boom in the vertical position (motor extended) so that the spring is in the lowest tension position, and lock the motor in this position.

In the threaded rod of the spring, there are two nuts:

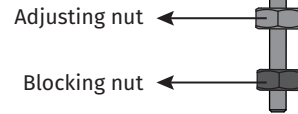

- 1 Give space to the spring threaded rod blocking nut.
- 2 By hand, pull the threaded rod down to keep the spring stretched but tension free.
- 3 Keeping the spring in this stretched position, tighten the adjusting nut until it touches the plate.
This is the initial position for spring adjusting.

- 4 Hold the threaded rod with pliers to prevent it from turning, and keep tightening the adjusting nut until the spring is stretched by the distance mentioned in the table on page 12A.

- 5 After stretching the spring, unlock the motor and test the balance between the spring and the boom, performing the test on page 12B.

- 6 If the boom is not balanced, tighten or loosen the adjusting nut to achieve the best possible balance.

- 7 After the spring adjustment is finished, tighten the blocking nut until it touches the adjustment nut. In this way, you will lock the adjustment position, to ensure that the spring does not go out of adjustment.

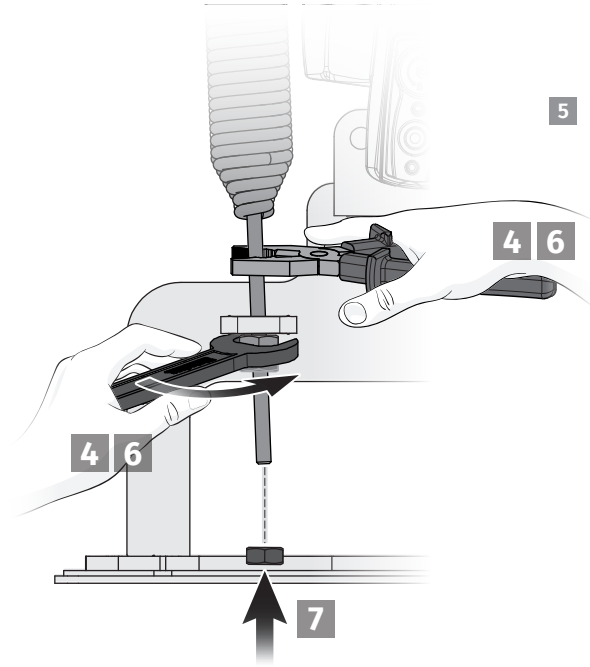

i • **ADJUSTING EXAMPLE**

*In this example a 5M boom is considered, which requires a 23mm tunning (see tables on page 12A), where the M8 rod starts 20mm below the support plate (INITIAL POSITION).

20mm

ADJUSTING 23mm

MEASURE WITH ADJUSTMENT 43mm

03. INSTALLATION

ADJUSTING TABLES

• LEVER HOLES

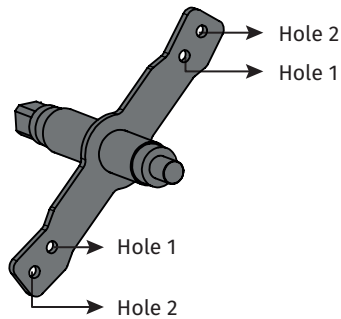

		5000	4500	4000	3500
SPRING	Hole:	Hole 2	Hole 2	Hole 1	Hole 1
	Adjustment:	23 mm	15 mm	1 mm	27 mm
MOTOR	Hole:	Hole 2	Hole 2	Hole 2	Hole 2

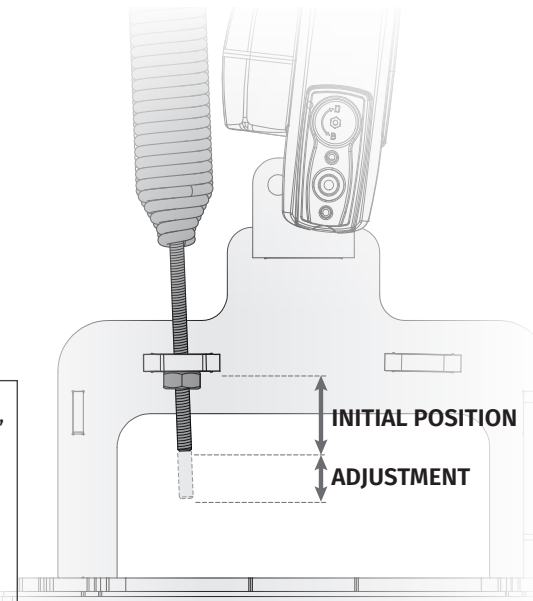

- Depending on the state of the spring, there may be a tolerance of 5mm in relation to the values indicated in the table.
- It should test the minimum necessary adjustment in order to compensate for the weight of the boom.

03. INSTALLATION

TESTING SPRING ADJUSTMENT



The motor must remain unlocked to perform the tuning test.

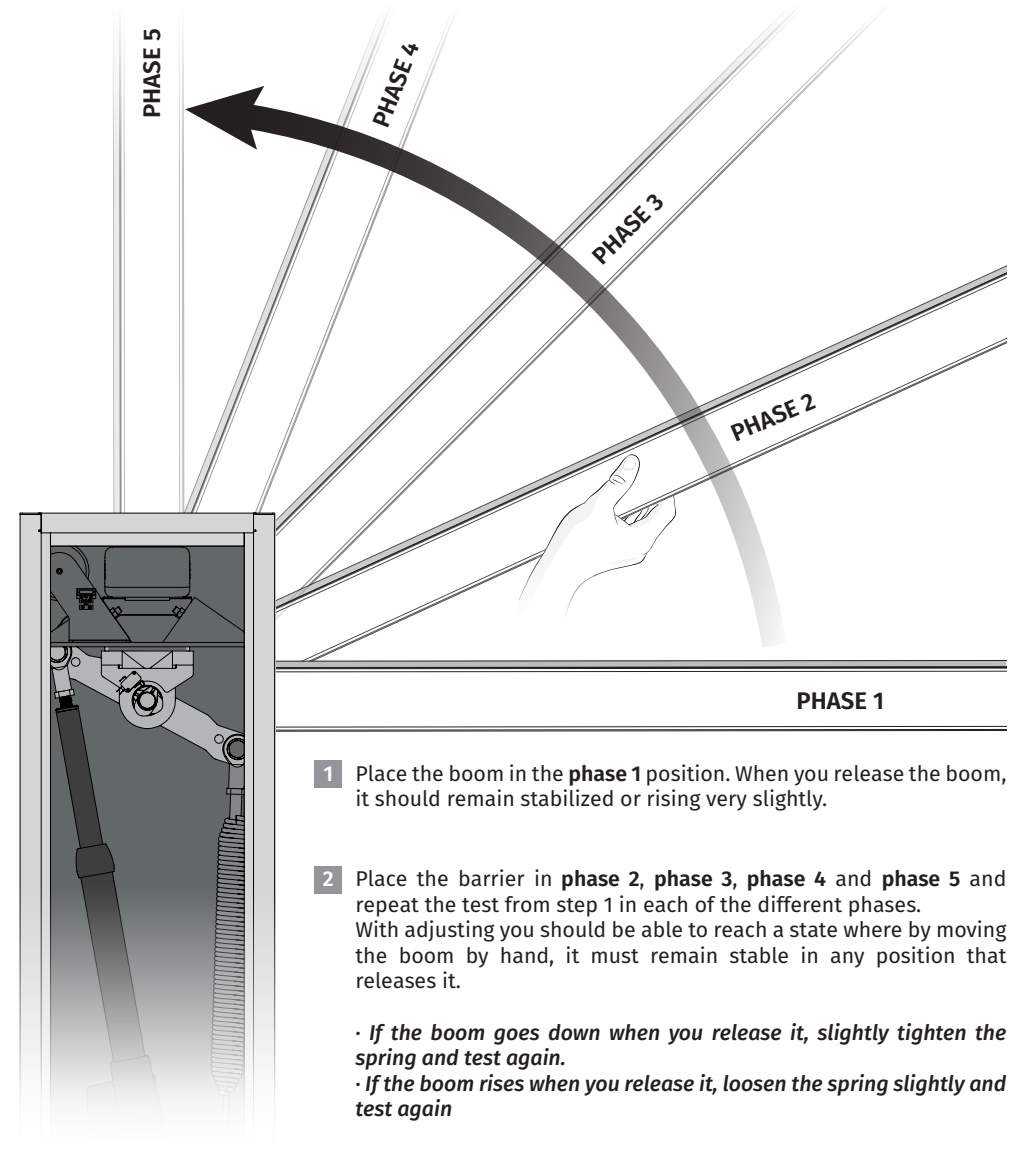

- 1 Place the boom in the **phase 1** position. When you release the boom, it should remain stabilized or rising very slightly.
- 2 Place the barrier in **phase 2, phase 3, phase 4** and **phase 5** and repeat the test from step 1 in each of the different phases. With adjusting you should be able to reach a state where by moving the boom by hand, it must remain stable in any position that releases it.

- If the boom goes down when you release it, slightly tighten the spring and test again.
- If the boom rises when you release it, loosen the spring slightly and test again

03. INSTALLATION

TUNING STOPPERS AND LIMIT SWITCHES

• ADJUST THE MECHANICAL STOPPERS

The mechanical stoppers present in the barrier are visible in the image below.

- They consist of 2 adjusting screws (one on each side of the barrier) fixed to the structure of the barrier.
- Each screw has a **blocking nut**.

• TUNE THE ELECTRICAL LIMIT SWITCHES

The electrical limit switches present on the barrier are visible in the image below.

- They are composed of 2 **limit switch micros** and 2 **actuators** (each one corresponding to opening and closing) fitted to the **central axis** of rotation of the boom.

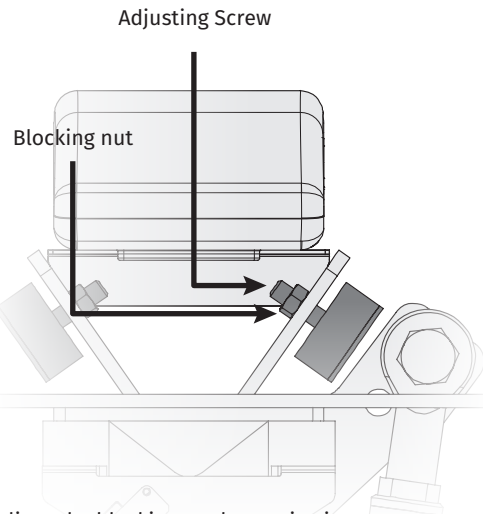

MECHANICAL CLOSING STOPPER

The closing limit switch is adjusted on the spring side with the boom in the closed position.

MECHANICAL OPENING STOPPER

The opening Limit switch is adjusted on the motor side with the boom in the open position.

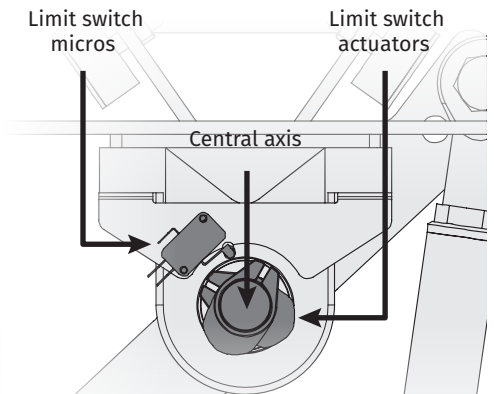
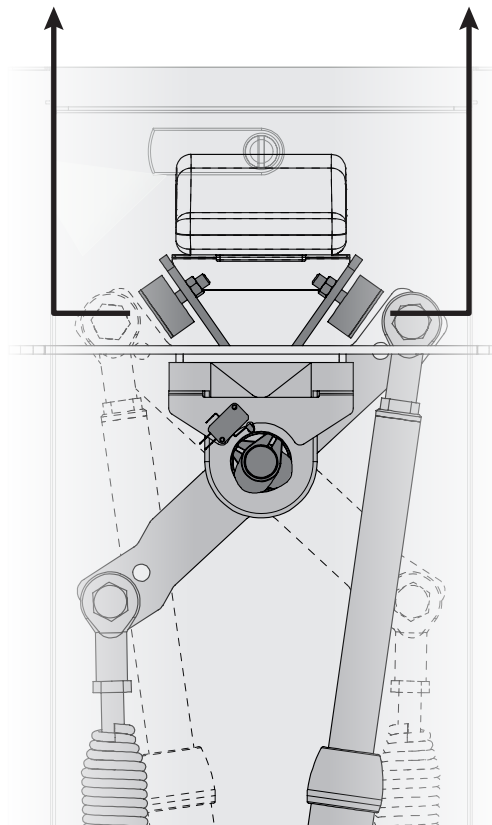

- 1 Relieve the blocking nut by moving it away from the lever.
- 2 Place the boom in a horizontal (closed) position.
- 3 Keeping the boom horizontal, turn the adjusting screw until its head touches the stopper plate.
- 4 After tuning the screw, tighten the blocking nut so that it does not become out of tune.

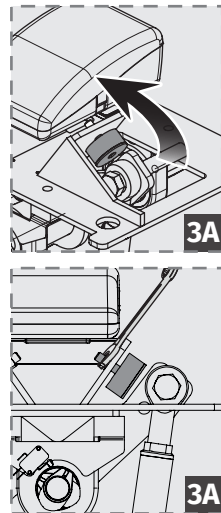

5

- 5 With the boom in the horizontal position (closing), loosen the set screw of the closing actuator and turn it until the point where it touches the micro lever.

6

- 6 Retighten the set screw to lock the closing limit switch actuation point.

Repeat steps 5 and 6 to adjust the opening limit switch (vertical boom).

6

03. INSTALLATION

POWER CABLE

*The barrier frame has a tube located on the inside so that it can conduct power wiring to the connectors (top of the barrier).

- 1 Pass the power cables coming from the ground through the pipe.

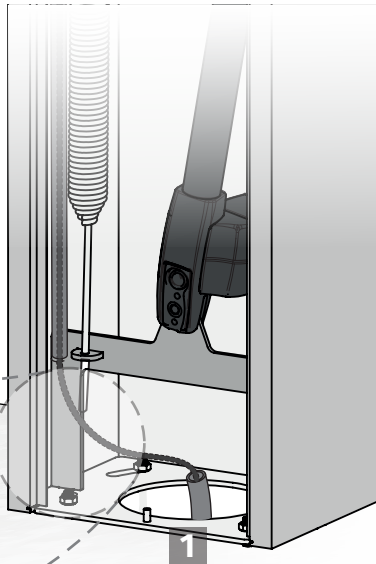

- 2 When the power cable reaches the barrier surface, connect the wires to the connector on the electronics support plate. Connect Ground Wire to the middle connector as in the picture.

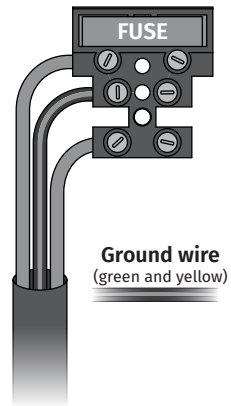
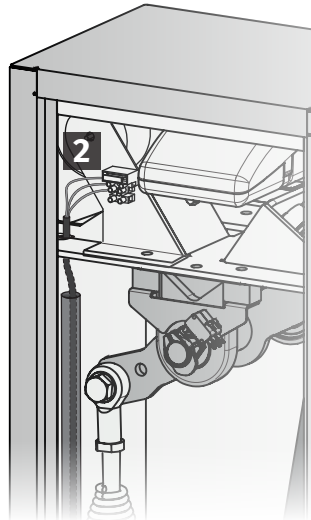

04. CONNECTIONS

CONNECTION SCHEME

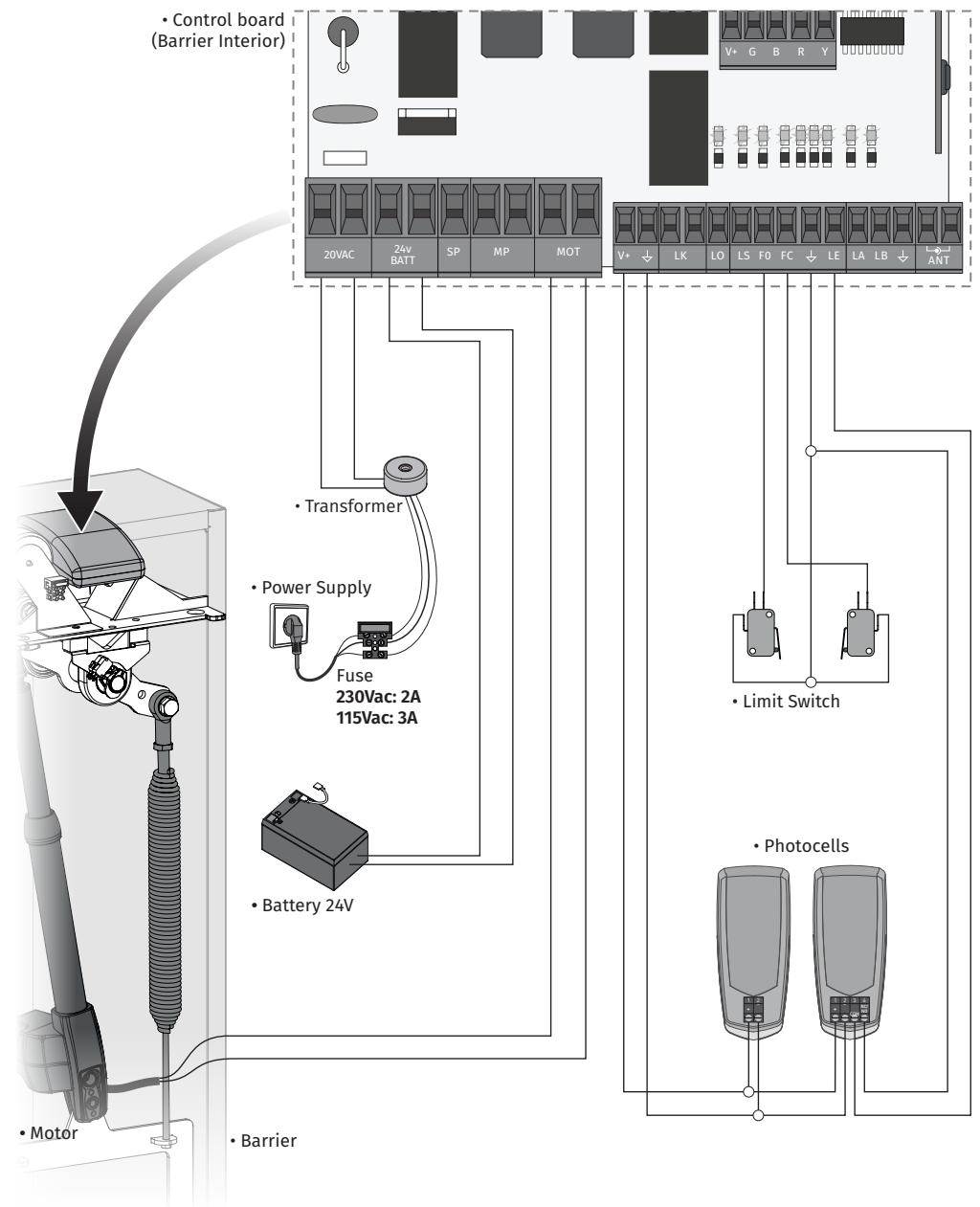

05. TROUBLESHOOTING

INSTRUCTIONS FOR FINAL CONSUMERS / SPECIALIZED TECHNICIANS

Anomaly	Procedure	Behavior	Procedure II	Discovering the origin of the problem
• Barrier doesn't work	• Make sure you have 230V power supply connected to automation and if the fuse working properly.	• Still not working	• Consult a qualified technician.	<ol style="list-style-type: none"> Remove the barrier top cover; Measure the 24V output of the transformer to detect the fault location; <p>A) Has 24V:</p> <ol style="list-style-type: none"> Verify if the control board is supplying the barrier to detect if the fault is in the motor or in the control board. Replace the damaged component or send it to the services for diagnosis and repair. <p>B) Has not 24V:</p> <ol style="list-style-type: none"> Verify the 230V input of the transformer. If have 230V the problem is in the transformer. If haven't 230V, the problem should be in the fuse, electric cables or in the power supply. Verify all the systems.
	• Verify the STOP	• Still not working	• Consult a qualified technician.	<ol style="list-style-type: none"> Give the opening order using a remote control and verify the behavior of the LEDs; Check signaling LEDs and limit switches connections. If everything is correct and there is no micro actuated, the LEDs will have to be on.. Check the entire circuit connecting the photocells to the control board. Check that STOP is activated (P6-LA). If activated and the circuit is not closed, the barrier will not work.
• Barrier doesn't move but makes noise	• Unlock the barrier and move by hand to check for mechanical problems.	• The barrier is stuck?	• Consult an experienced barrier expert.	<ol style="list-style-type: none"> Check all motion axis and associated motion systems related with the barrier, to find out what is the problem. Also check that the spring is in good condition and can support the barrier.
		• The barrier moves easily?	• Consult a qualified technician	<ol style="list-style-type: none"> Turn off the motor from control board and test it on directly to a 24V battery to find out if it is damaged; If the motor works, the problem is in the control board. Remove it and send it to the technical services for diagnosis; If the motor does not work, remove the motor and send it to the technical services for diagnosis.
• Barrier opens but doesn't close	<ol style="list-style-type: none"> Check if there is any obstacle in front of the photocells; Make sure if the photocells are working. Put your hand in front and check that the relay makes the noise. Check if any of the control devices of the barrier are stuck and sending permanent signal to control board; Check the safety edge connection. 	• Barrier opened but didn't close again.	• Consult a qualified technician	<ol style="list-style-type: none"> Verify if the display is connected to confirm the existence of power supply; Verify if the photocells are powered in control board output; Access the menu on the display and disable the photocells and the STOP; Check limit switch connections. If the 2 signaling LEDs are turned off, it means that the barrier can not operate because have the limit switches actuated. Try to close; <p>A) Closed:</p> <ol style="list-style-type: none"> Problem is in one of these two systems. Activate the photocells and check that the barrier closes. If close, problem will be in the STOP. Activate it the menu and try to close the barrier to be sure. <p>B) Doesn't closed:</p> <ol style="list-style-type: none"> Problem is in the motor or in the control board. Give an order to the barrier close while measuring the control board power output to the barrier. If it has 24V, the control board is working and the problem is in the motor. If it has not current, the problem is in the control board.
• Barrier doesn't make complete route	• Unlock the barrier and move by hand to check for mechanical problems.	• Encountered problems?	• Consult an experienced barrier expert.	<ol style="list-style-type: none"> Check all motion axis and associated motion systems related with the barrier, to find out what is the problem. Also check that the spring is in good condition and can support the barrier.
		• The barrier moves easily?	<ol style="list-style-type: none"> Re-program the limit switches; Consult a qualified technician 	<ol style="list-style-type: none"> Verify if the tests to the barrier were well made; Change the force of P2 menu until the barrier moves without changing the direction; This adjustment should be made in such a way that the barrier, when encountering an obstacle, reverses; If even at maximum force level (F0=09) is still the problem, test the barrier directly connected to a 24V battery to see if it has the power to open / close the barrier completely; Change the force in the P2 menu until the barrier moves without changing the direction;